

FINAL (CAMERA-READY) PAPER PREPARATION AND SUBMISSION INSTRUCTIONS FOR EUSIPCO 2007 (WORD SAMPLE FILE)

First Author, Second Author, and Third Author

Institute/Department of Yours, Your University
University Address, Zip, City, Country

phone: + (int. code) your phone, fax: + (int. code) your fax, email: your-email@address.edu
web: www.server

ABSTRACT

EUSIPCO 2007 welcomes the submission of high-quality papers in all areas of Signal Processing. This manuscript (Microsoft® WORD example file) uses preformatted WORD styles, which stick to the format and style instructions for EUSIPCO 2007. These instructions are presented and some general information regarding paper preparation and submission is provided.

1. GENERAL INFORMATION

The purpose of the instructions collected in this manuscript is to specify the format and style of admissible EUSIPCO 2007 papers and to facilitate paper submission. First of all, here is some general information about the paper preparation.

- Papers submitted to EUSIPCO-2007 must describe original, unpublished work. The papers must contain a complete description of the ideas presented and applicable research results.
- Please note that no person may appear as author (first author or co-author) on more than **four** papers.
- Papers must conform to the format and style specified in Section 2. The deadline for the submission of final camera-ready papers is June 10, 2007. The maximum paper length including figures and references is **five** (5) pages. The only accepted submission form is WWW-based upload of Adobe© **PDF files**.
- All submitted anonymous papers that conformed to the style instructions specified in Section 2 were reviewed by reviewers selected by the conference committee for their demonstrated knowledge of particular topics. The review process was carried online and the results of the reviewing are posted on EUSIPCO 2007 website. Authors were also notified of the review results by E-mail.
- Based on comments from the reviewers, it is now possible to make changes to your paper before it is submitted in its final, camera-ready form on June 10, 2007.
- Accepted papers will be published in the EUSIPCO 2007 Proceedings (CD-ROM).
- Best paper awards will be presented to authors with student status. The **student** author's name must appear **first** on the paper.

- At least one author of each accepted paper **must register** for the conference no later than June 10, 2007. (The EUSIPCO 2007 registration site will be opened in due time)

2. PAPER FORMAT AND STYLE

In case of acceptance of your paper, the electronic final (camera-ready) paper version (**PDF file**) submitted by you will be directly reproduced in the EUSIPCO 2007 Proceedings. Your strict adherence to the format and style specifications described in this section is **necessary** to maintain uniformity of appearance throughout the Proceedings. Although this “sample paper” was typewritten using Microsoft® WORD, by no means EUSIPCO 2007 suggests or requires that your paper be prepared using such software.

2.1 Format

- The maximum paper length including figures and references is **five** (5) pages of **A4 size** (210 x 297 mm).
- All material must fit in a 176 x 240 mm (6.93 x 9.45 inch) area of the A4 page with a left margin of 17 mm (0.67 inch) and a top margin of 25 mm (1 inch). On the first page, the top margin has to be 32 mm (1.26 inch).
- All text **must appear in two columns** with a column spacing of 6 mm (0.24 inch). Figures and tables may span the two columns if necessary.
- **Do not put page numbers on your document.** We will add appropriate page numbers to accepted papers when the conference proceedings are assembled.

2.2 Style

- All text must be single-spaced.
- The recommended font size is 10 point. The font size must be at least 9 point (capital letters at least 2 mm high) and at most 11 point.
- The recommended font is Times Roman or Times New Roman.
- The recommended paragraph indentation is 7 mm.

2.2.1 Title Area

- The paper title is to appear in boldface capital letters, centered across the top of the two columns on the first page. The recommended font size for the paper title is 13 point.

- A 4 cm blank space should be left below the title (in the camera-ready version, names and affiliations will be written there).

2.2.2 Abstract

- The paper abstract appears below the title area on the first page as the first item on the left-hand column.
- The text of the abstract should be in *italic* letters.
- Allow 11 mm vertical space between title area and abstract.
- The abstract should not contain more than 150 words.

2.2.3 Headings

- Major headings should be numbered and appear in boldface capital letters, centered within the respective column.
- Subheadings should be numbered, left aligned in the respective column, and in boldface letters.
- Sub-subheadings—if they cannot be avoided—should be left aligned in the respective column and in italic letters; they may be numbered.

2.2.4 Equations

Equations should be centered within the respective column, e.g.,

$$C = \frac{1}{2} \log_2 \left(1 + \frac{P}{\sigma^2} \right). \quad (1)$$

We recommend labelling only those equations that are referenced in the paper. Base font size for equations should be the same as the main text. Please, pay attention to proper alignment of formulas and mathematical symbols embedded into the text.

2.2.5 Figures and Tables

- All figures and tables must be referred to in the paper. They must be numbered and have captions (see example format of Table 1 and Fig. 1).
- Use vector graphics for diagrams whenever possible.
- Bitmapped pictures must have a proper resolution in order to ensure readability. They may be in colour provided that they appear clearly when printing in grey shades.

Table 1 – Table captions should be positioned above tables. This table format is recommended, but not obligatory

Name	N	SNR [dB]	Error [%]
Lena	16384	28	0.0001
Boats	1024	36	0.01

2.2.6 References

- References are numbered either in order of appearance in the paper or in alphabetical order.
- They are referred to by the respective reference number enclosed by square brackets (e.g., [2,3]).

2.3 Technical issues

- Turn off lossy compression of bitmapped images in your PDF generation software if reproduced images are supposed to present artefacts. Note that compression is switched on by default in Adobe Acrobat.

- All fonts used must be embedded in the PDF file. However, Asian fonts must **not** be used nor embedded. Documents that do not print correctly on a PostScript printer cannot be accepted. (When printing the PDF file, make sure that the "shrink to fit" box is **not checked!**). Providing a correct and printable PDF file is entirely under the authors' responsibility.
- Since your paper will be published to CDROM as well as other web based rendering platforms, it is extremely important for you to produce a clean copy of your file using **NO Type 3 fonts**. This restriction affects users of LaTeX on Unix systems, where LaTeX uses Type 3 fonts by default.
- Do NOT apply security settings to your PDF file.
- **The file size limitation is 2.0 MB.**

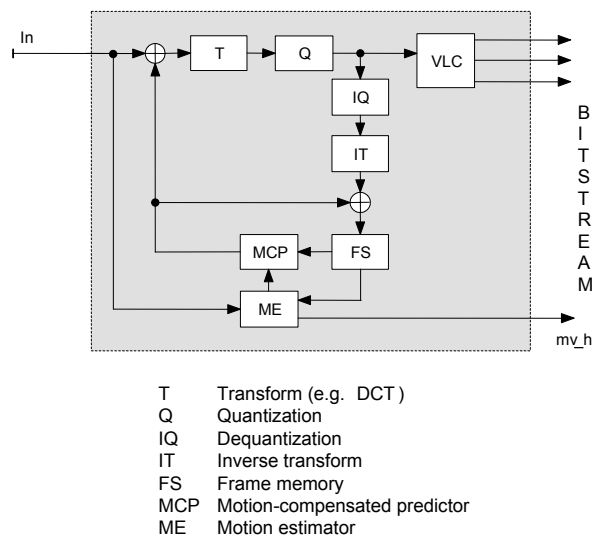

Figure 1 – Figure captions should be positioned below figures

3. SUBMISSION

Submission of final papers is carried by ePapers by using the same author account which was used for submitting anonymous papers for review. All files must be submitted to ePapers through the EUSIPCO 2007 web page at

<http://www.eusipco2007.org/>

under the menu item *Camera Ready Papers* on your left-hand side of the webpage. You have to use the user ID and password selected when submitting your anonymous paper.

After logging in to your account, you may choose your PDF file for upload at the bottom ("*Upload File*" string) of the page. Your browser will upload your file to the ePapers server. At the end of a successful upload, you will see a confirmation page displaying the size of the file in bytes and the uploading date. An E-mail message will be sent to the authors' E-mail addresses to confirm that the file has indeed been uploaded. If you do not see the confirmation page or the E-mail after uploading your file, we may not have successfully received your file upload. If you encounter trouble, contact the paper submission support at:

wd@epapers.org .

Further information on the upload procedures and/or on the rules to prepare a final camera-ready paper can be obtained from the contact person of the organizing committee, support@eusipco2007.org .

4. REGISTER FOR THE CONFERENCE

Be sure that at least one author registers to attend the conference using the online registration system available through the conference website:

<http://www.eusipco2007.org> ,

under the menu item *Registration* on your left-hand side of the webpage. Each paper must have at least one author registered. The **full payment must be received** by the deadline

of the author registration. It is expected that **each paper will be presented by one of its authors**.

5. IMPORTANT DATES

Camera-ready final paper due:	June 10, 2007
Deadline for authors' registration:	June 10, 2007

REFERENCES

- [1] A. B. Author, *Title of Book*. Address: ABC Press, 2000.
- [2] A. B. Author and C. Author, "Title of journal paper," *Title of Journal*, vol. 1, pp. 11–25, Jan. 1999.
- [3] A. B. Author, C. Author, and D. E. Author, "Title of conference paper," in *Proc. EUSIPCO 2007*, Poznań, Poland, September 3-7. 2007, pp. 111–115.